

Co-supervised Master thesis, 2021-2022

Comparison of Inversion-based control and state feedback control for SIRIUS_FP2P2S power converters

Supervisors: A. Bouscayrol, P. Delarue, L2EP – J. M. Cravero, D. Agugula, CERN

Contact: Alain.Bouscayrol@univ-lille.fr

Context

CERN is the well-known international research centre on physics of particles with of the most important particle collider in the world (27 km). Active research are preparing the next generation of accelerators for the discovery of new particles and matter. In particular, new power electronics converter are developed with higher modularity, high current, fast dynamics and very high accuracy.

The Sirius FP2P2S is a new generation for particle injectors with current pulse of 1 ms, up to 2700A, with an accuracy of +/- 3A. Such performances can be achieved only with a very high-precision control. In that aim, CERN has developed an inversion-based control based on Energetic Macroscopic Representation, a graphical formalism developed by L2EP for model and control organization of complex systems.

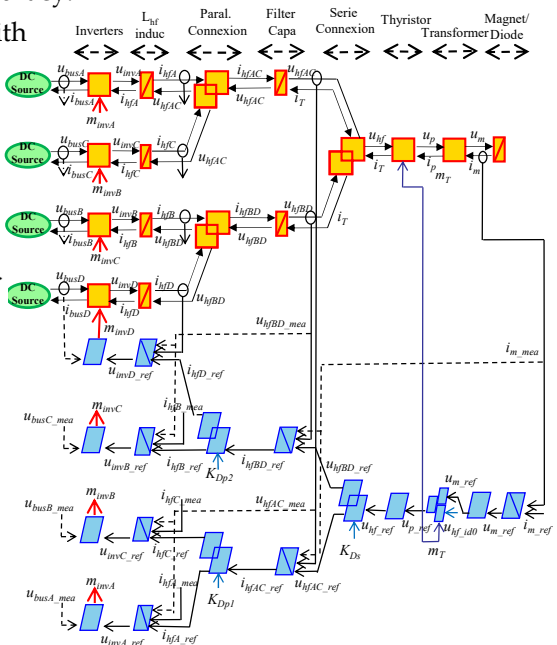
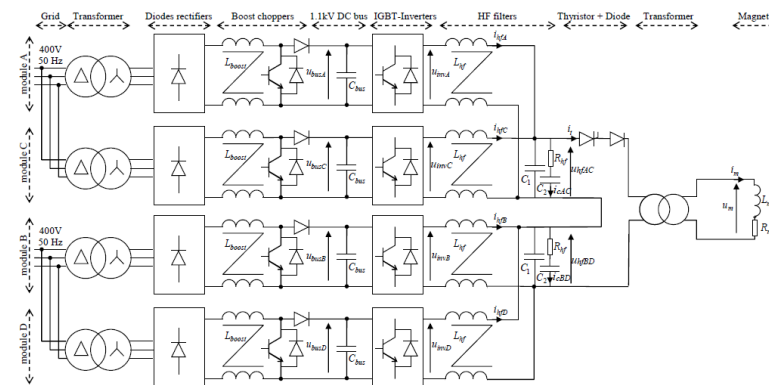

In 2019 a new collaboration between L2EP and CERN has compared the performance of this EMR-based control and another classical method used by other team of CERN, a RST-based control.

Objective

In order to continue the collaboration, a new comparative study is defined. The EMR-based control of this high-accuracy converter will be compared with another classical method used by other team of CERN; the state feedback control.

The EMR-based control in its analogic and digital version should be first studied and analysed. In e second step, a state feedback control of this converter should be defined. Finally a comparison of both control methods will highlight their interest and limitation.

References

[Bouscayrol 2012] A. Bouscayrol, J. P. Hautier, B. Lemaire-Semail, "Graphic Formalisms for the Control of Multi-Physical Energetic Systems", Systemic Design Methodologies for Electrical Energy, tome 1, Analysis, Synthesis and Management, Chapter 3, ISTE Willey editions, October 2012, ISBN: 9781848213883.

[Horrein 2017] L. Horrein, J. M. Cravero, "Hybrid Capacitor Discharge/Switch-Mode Converter for Pulsed Applications: Topology and Control design", EPE'17 ECCE Europe, Warsaw (Poland), Sep. 2017.

[Horrein 2020] J L. Horrein, J. M. Cravero, P. Delarue, A. Bouscayrol, D. Aguglia, C. Ortega-Perez, "Dead-Time influence on fast switching pulsed power converters design - A high current application for accelerator's magnets", EPE'20 ECCE Europe, Lyon (France), September 2020 (common paper of L2EP Univ Lille and CERN).