

ENERGY STORAGE SYSTEMS IN DISTRIBUTION GRIDS: NEW ASSETS TO UPGRADE DISTRIBUTION NETWORKS ABILITIES

Gauthier DELILLE
EDF R&D and L2EP – France
gauthier.delille@centraliens-lille.org

Bruno FRANÇOIS
L2EP – France
bruno.francois@ec-lille.fr

Gilles MALARANGE
EDF R&D – France
gilles.malarange@edf.fr

Jean-Luc FRAISSE
ERDF – France
jean-luc.fraisse@erdfdistribution.fr

ABSTRACT

This paper deals with distributed energy storage systems and reviews the services such devices can provide to the stakeholders of the electricity value chain. The combination of these applications to increase the overall value of energy storage is then studied using a new method.

INTRODUCTION

In the future, DSO will continue to face many challenges such as increasing peak loads, more and more severe power quality requirements and the continuous development of dispersed generation (DG).

To offer reliable services to their customers, DSO must take advantage of new technical options to support conventional solutions for utility distribution systems. Among these innovative alternatives, Distributed Energy Storage Systems (DESS) offer interesting features and have received considerable attention lately. However, they still remain capital-intensive and raise cost-competitiveness issues.

This paper deals with the potential of DESS to support and to optimize distribution system operation. First of all, some general information about DESS and their technical performances is given. Then, an overview of their applications in liberalised power systems is drawn (for DSO and other stakeholders). In the last part, a new approach to the combination of storage benefits is introduced and its use within the framework of this project is briefly discussed.

DISTRIBUTED ENERGY STORAGE SYSTEMS

The generic structure of a DESS is illustrated in Figure 1. The component in which the energy is stored is referred to as the Energy Storage Device (ESD). Various storage techniques have been used so far for stationary applications and many others are still at a pre-commercial or R&D stage. The suitability of about twenty storage technologies for medium-term (2015) integration into distribution systems was investigated in a previous work [1]. Nine technologies eventually stood out as they seemed to best meet the requirements of distribution systems (see Table 1): seven “standard”, high-temperature or redox-flow batteries (Pb-acid, NiMH, Li-ion, NAS, ZEBRA, VRB, ZnBr), plus flywheels and ultracapacitors.

All the selected technologies have DC power output or variable-frequency AC output (flywheels). A Power

Conversion System (PCS) is thus used to interface the ESD to the AC grid. It usually includes a power electronic inverter, monitoring/control systems, protective devices, a step-up transformer and harmonic filters. Additional converter(s) can be required to match the output voltage level and/or waveform of the storage device to the DC bus, or to control power flows in parallel multi-string or multi-storage configurations. Some ancillary equipment is often needed to perform functions such as ESD and PCS cooling.

Technology	Feasible power range (system)	Nominal discharge time	DC round-trip efficiency
Pb-acid	f.kW-f.10MW	2-8h	70-85%
NiMH	f.kW-f.MW	f.10min-hours	65-75%
Li-ion	f.kW-1MW	f.10min-hours	85-90%
NAS (high T°)	50kW-f.10MW	7-9h	85-90%
ZEBRA (high T°)	5kW-500kW	2-10h	85-90%
VRB (redox flow)	f.kW-10MW	f.hours (flexible)	80-85%
ZnBr (redox flow)	25kW-f.MW	2h30	75-80%
Flywheel	f.kW-f.10MW	10s-f.minutes	85-95%
Ultracapacitor	f.kW-f.MW	1s-f.10s	85-98%

Table 1: The nine selected energy storage technologies and some of their characteristics (f.=a few) [1].

Current indicative best investment costs for MW-scale DESS range from less than 1000€/kW for short-term operations (e.g. power quality) to more than 2500€/kW for long-term operations (e.g. peak shaving) [1][2][3][4].

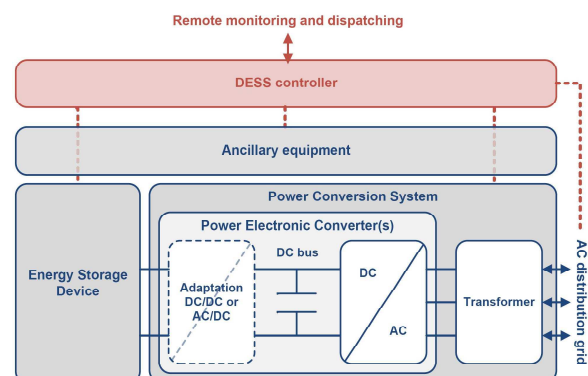

Figure 1: Typical layout of a DESS.

POSSIBLE SERVICES PROVIDED BY DESS

In metropolitan France, medium-voltage (MV, mainly 20kV) and low-voltage (LV, exclusively 400V) distribution systems are operated either by ERDF, the national distribution network subsidiary of EDF or local electric distribution utilities (LED). Within the framework of this

project, the potential of DESS was discussed with ERDF, three LED and EDF Island Energy Systems in order to identify the most interesting services of DESS from the point of view of DSO.

To increase the profitability of energy storage, it was decided to analyze the potential for combination of DESS benefits. We thus contemplate herein the possible services of energy storage not only for DSO, but for some other stakeholders of the electricity value chain as well.

Services of DESS for distribution system operators

Capacity support (DSO1)

In capacity support application, a storage unit is used to shift load from peak to baseload periods in normal operating situation. The DESS is charged when the current flowing through the considered, constrained grid assets is low and discharged later when this current is high.

This application allows the DSO to delay utility investment in grid capacity reinforcement (for example multi-MVA HV/MV substation transformer) by using relatively small amounts of storage: the rated power of the DESS must at least match the expected load growth for a given planning time, typically between 500kW and a few MW at MV-level. The required nominal discharge time strongly depends on the local load profile and is in the range 2-10h.

The benefit of such a deferral for the DSO equals to the net present value saved by delaying the upgrade [4] and is very dependant on the local grid configuration. It is estimated in [2] with Californian figures to be in the range \$666-1067 per kW of storage capacity, if installed. Other benefits may be taken into account, such as equipment life extension due to reduced thermal overloads and buy-low/sell-high "incidental" revenue stream on the market.

For example, the reference [3] deals with a 1MW/7.2h NAS DESS to delay the building of a new substation (US-WV). This system successfully performed a 3-year upgrade deferral and is currently being relocated to a different site.

Dynamic, local voltage control (DSO2)

DESS may help to maintain the voltage profile within admissible contractual/regulatory limits. In distribution grids, voltage support can rely both on reactive power (made possible for DESS by power electronics) and active power modulations. The main benefit derives from the deferral of distribution upgrades that would otherwise be necessary to meet the voltage level requirements.

To perform the capacity support application described above, the DESS should preferably be located directly downstream capital-intensive, constrained assets. On the contrary, the effect of local voltage control is proportional to the impedance (R_{line} ; X_{line}) between the considered connection point and the substation, where voltage control is performed by the on-load tap changer of the HV/MV transformer. Calculations show that punctually increasing the local voltage profile by a few % requires a DESS

between a few 100kW (kvar) and a few MW (Mvar) for a MV feeder. If this service is performed through injection of active power, the discharge time depends on the local load profile and is in the same range as capacity support (2-10h).

Contingency grid support (DSO3)

Capacity and/or voltage support can be performed in normal operating situation, as discussed above. They might as well be useful in emergency situation, for example after loss of a major component of the distribution grid.

In anticipation of such events, French MV-distribution feeders are usually loopable (but radially operated): they can be energised by a neighbouring feeder powered by another HV/MV transformer. This "N-1" condition is taken into account within distribution planning with slightly less severe constraints than in normal situation. Nevertheless, it can lead in some cases to large oversizings with respect to the requirements of normal operating conditions.

For this service, it is worth noting that the DESS works as a current injector and not as a voltage source (islanding). As it is a particular case of the applications DSO1/DSO2, data about operational principles and sizing can be found in the corresponding sections above. Additional benefits brought by contingency support include a decrease in the impacts of a component failure (outage frequency or duration).

Discussion and complementary applications for DSO

These first three DESS applications were found particularly interesting by the questioned DSO. It is worth noting that they all appear to be related to distribution planning. Their effective economic interest should therefore be evaluated through standard cost/benefit analysis taking into account both investment and exploitation costs (e.g. energy losses).

Several other possible DESS services were examined, such as **islanding (DSO4)**, which consists in using DESS to energize a non-loopable feeder during an outage. In such a black start application, the DESS works as a voltage source. The benefits for the DSO in terms of service reliability are easy to understand, but severe technical questions must be tackled, such as the adaptation of existing protection schemes to allow for operation at weak short circuit power.

Reactive power compensation (DSO5) can be provided by an existing DESS thanks to the capabilities of its PCS.

Distribution power quality is made possible by power electronics as well but appears to be a niche application. Finally, load levelling performed with storage **reduces line losses**, but case studies were carried out and showed that the possible energy savings are much smaller than the additional losses in the DESS itself, even with current state-of-the-art devices (AC round-trip efficiency of 75-80%). In the best case scenario, the line loss reduction at MV level only makes up for a few 10% of the losses in the DESS.

Services of DESS for other stakeholders

DESS used to upgrade distribution abilities can be made more profitable by providing services to other stakeholders

in addition to distribution system operators, providing that a suitable agreement is found between the involved players. Some possible applications are briefly reviewed hereafter.

First, DESS might be used for bulk energy arbitrage (BEA) as a complementary revenue stream for the storage operator. In France, the potential annual benefit was calculated using Powernext spot prices to be in the range 25-75€/kW depending on the discharge time of the storage media. However, because of economy of scale and lower access charge at transmission level, DESS cannot compete with large-scale facilities such as pumped hydro.

Services for conventional generation operators

In large interconnected power systems such as UCTE, it seems quite difficult for DESS to have significant impact on the everyday operation of conventional generation. However, in island power systems, the situation is quite different (higher sensitivity to perturbations, higher costs...) and some services may thus be considered. For instance, in isolated grids, storage can be used as a **peaking capacity (GEN1)** instead of an emitting technology like combustion turbines. For such a service, MW-scale units with several hours of discharge are required. This application will be experimented soon by EDF Island Energy Systems (1MW/7.2h NAS battery) at Reunion Island.

Besides, DESS operating in island power systems can contribute to reduce the stress on central generation facilities (e.g. when used in renewable output smoothing), thus potentially decreasing their fuel consumption (and subsequent emissions) or increasing their lifetime. We will refer to this possible additional benefit of distributed storage as **conventional generation support (GEN2)**.

Services for the Transmission System Operator (TSO)

As studied in [4], DESS can participate to the **primary frequency control (TSO1)**. According to UCTE rules, this reserve should be fully activated within 15-30s and capable of lasting 15 minutes, leading to a required DESS discharge time between about 20 minutes and 1h according to the literature. To be observable by the TSO and considering that the security and the quality of electricity supply are at stake, DESS used to provide control power should not be smaller than a given limit, say for instance 1MW. In island systems, the feasible very prompt response of DESS can be interesting from the point of view of **frequency stability (TSO1-i)**, by helping to avoid load shedding. This application requires a very short response time (<1s) and a discharge duration of a few 10s.

Other services were investigated, such as participation to **secondary frequency control, voltage control, congestion relief, line loss minimization** or **transmission stability**, but were all found to be rather complementary applications.

Services for Renewable DG operators

At present, renewable DG operators usually do not participate to ancillary services apart from some particular cases like in Denmark or Ireland. For renewable-based DG,

contributing to frequency control implies keeping some reserve power, thus “wasting” a part of the resource. Hence, when the contribution of renewable-based DG to primary frequency control is compulsory, storage can be considered as an interesting way to provide control power instead of a voluntary degradation of primary energy conversion. This **“ancillary services DG support (DG1)”** enables the producer to maximize the use of its available power and to provide guaranteed control power to the system, which by the way would not be possible otherwise because of the variability of renewable sources.

Short-term fluctuations smoothing (niche application), **transmission curtailment, time-shifting** or even **capacity firming** (all three requiring high amounts of storage) seem less promising than DG1 on a short-term perspective.

Services for customers

Following the example of what has been done for many years with diesel generators, energy storage can be used by (industrial) customers for **peak shaving (CUS1)** in order to minimize the part of their invoice that varies according to their highest power demand [4]. Such a service might be profitable if the peaks are sufficiently predictable and of relatively short duration, leading to savings up to about 100€/kW depending on the applicable peak tariff.

Besides, considering the current energy supply prices in France, it was found that **time-of-use energy cost management** can hardly make up for the losses in the storage system, with just a few possible €/kW of additional profit. **End-user power quality/continuity** (usual applications of uninterruptible power supplies) and **reactive power compensation** are other possible options.

COMBINATION OF DESS SERVICES

Storage can be useful in many ways to the stakeholders of the electricity value chain, but considering only a single revenue stream is often very insufficient to exceed the costs of the device and to reach profitability. Therefore, the combination of DESS services should be contemplated as a solution to enable the use of distributed storage by sharing its benefits between several players, including DSO.

In this last paragraph, the combination of storage services is studied. With this aim in view, we consider the nine “typical” connection points defined in Figure 2. For technical or regulatory reasons, the applications identified above can be more or less easily performed depending on the location of DESS in the grid. That is why a matrix assessing the feasibility of some thirty services for the considered positions was built as a support for the analysis.

Table 2 is an extract from this tool limited to the most promising applications of DESS. **Storage connection at the HV/MV substation or at a “prosumer” facility connected to the MV grid (association of locations D and E) appear to provide the largest ranges of options.** Once a location is chosen, possible DESS “service packs” can be

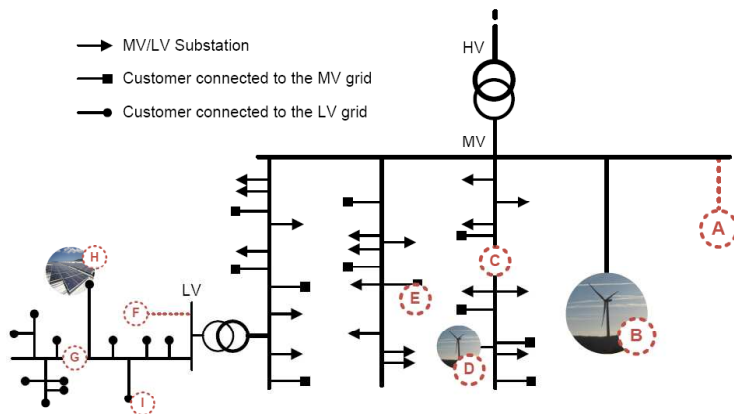

Storage location	
A	At HV/MV substation
B	At DG unit connected to a dedicated feeder
C	At any point of an existing MV feeder
D	At DG unit connected to an existing feeder
E	At customer facility connected to MV grid
F	At MV/LV substation
G	At any point of an existing LV feeder
H	At "prosumer" facility connected to LV grid
I	At customer facility connected to LV grid

Figure 2: Definition of typical locations for DESS benefits combination analysis.

read on the matrix. The options must then be studied on a case by case basis, taking into account many technical, economic, regulatory and environmental aspects.

CONCLUSION AND ONGOING RESEARCH

This paper gives general information about distributed energy storage systems and reviews the services they can provide to the stakeholders of the electricity value chain. A new method to study the combination of these applications to increase the overall value of storage is proposed.

Ongoing research includes further developments concerning the combination of storage services. Best cases identified with the locations vs. services matrix (notably DESS at a MV-connected "prosumer" facility) are currently being studied through dynamic and real-time simulation.

REFERENCES

[1] G. DELILLE, B. FRANÇOIS, 2008, "A Review of Some Technical and Economic Features of Energy Storage Technologies for Distribution System Integration", *Proceedings Electrical Machines, Drives and Power Systems (ELMA)*, Bulgaria, vol.1, 67-72.

[2] EPRI-DOE Handbook of Energy Storage for Transmission and Distribution Applications, EPRI, Palo Alto, CA, and the US Department of Energy,

Washington, DC: 2003. 1001834.

[3] NOURAI A., 2007, *Installation of the First Distributed Energy Storage System (DESS) at American Electric Power (AEP)*, Sandia National Laboratories, SAND2007-3580.

[4] OUDALOV et al., 2006, "Value Analysis of Battery Energy Storage Applications in Power Systems", *Proceedings IEEE PES Power System Conference and Exposition (PSCE06)*, Atlanta, 2206-2211.

ACKNOWLEDGEMENTS

This work was funded by EDF and ADEME (French Agency for the Environment and Energy Management).

The authors kindly acknowledge Mehana CHAMI (EDF R&D), Joseph MAIRE (EDF R&D) and Stéphane BISCAGLIA (ADEME).

Table 2: Locations vs. services matrix (f.=a few).

	Ideal location for the considered service
	Possible location for the considered service
	Inappropriate location for the considered service
●	Possible high-value application of energy storage (symbol ■ if specific to island power systems)
○	Complementary application of energy storage (symbol □ if specific to island power systems)

Service	Required power	Required indicative discharge time	Required storage response time	Frequency	MV voltage					LV voltage				
					A	B	C	D	E	F	G	H	I	
DSO1	500kW-f.MW (MV) f.100kW (LV)	2-10h	Minutes	Occasional (peaks)	●	●	●	●	●	●	●	●	●	●
DSO2	100kW-f.MW (MV) 10kW-f.100kW (LV)	2-10h	Minutes	Occasional (peaks)	■	●	●	●	●	●	●	●	●	●
DSO3	100kW-f.MW (MV) 10kW-f.100kW (LV)	2-10h	Minutes	Exceptional	●	●	●	●	●	●	●	●	●	●
DSO4	100kW-10MW (MV) 10kW-1MW (LV)	4-10h	20ms	Exceptional	○	○	○	○	○	○	○	○	○	○
DSO5	f.100kvar-f.Mvar	Reactive power	Minutes	Daily	○	○	○	○	○	■	■	■	■	■
GEN1	At least 1MW	1-10h	Minutes	Daily	■	■	■	■	■	■	■	■	■	■
GEN2	At least 1MW	Variable	Variable	Variable	□	□	□	□	□	□	□	□	□	□
TSO1	At least 1MW	20min-1h30	15-30 seconds	Continuous	●	●	●	●	●	■	■	■	■	■
TSO1-i	At least 1MW	f.10s	Less than 1 second	Exceptional	■	■	■	■	■	■	■	■	■	■
DG1	f.100kW-2MW	20min-1h30	15-30 seconds	Continuous	●	●	●	●	●	■	■	■	■	■
CUS1	0,5-10MW	1-10h	Minutes	Occasional (peaks)	■	■	■	■	■	■	■	■	■	■
BEA	At least 1MW	A few hours	Minutes	Daily	○	○	○	○	○	○	○	○	○	○